

GENERAL

The Caproco retrievable injection/sampling system consists of a tee access fitting with a solid plug assembly, to which a tube is fitted by means of an injection nut. Where applicable, a nozzle may be fitted to the tube for injection purposes. Injection/sampling is done through the tee of the access fitting body, using a nipple and shut-off valve to connect to the injection liquid source or sampling delivery point. An optional check valve is available to ensure that the fluid in the system does not back flow to the injection equipment if for any reason the pressure in the injection system falls below the line pressure.

INJECTION/SAMPLING ASSEMBLY

The standard Caproco retrievable injection or sampling assembly is comprised of the following components:

- Tee Access Fitting Body (with optional protective cover)
- Solid Plug Assembly
- Injection Nut
- Injection Tube / Sampling Tube
- Injection Nozzle (if applicable)
- Threaded Nipple
- Shut Off Valve
- Check Valve (optional)
- Feed Pump and an Injection Liquid Tank (usually customer supplied)

SPECIFICATIONS

Maximum Operating Pressure	3,600 / 6,000 psi (24.8 / 41.4 MPa)
Maximum Operating Temperature	500 °F (260 °C)

The access fitting body is manufactured from carbon steel and the solid plug, injection/ sampling nut and tube, valve and nipple are all manufactured from stainless steel. Other materials/designs are available to meet the specifications of virtually any application.

Standard valves are rated to a maximum working pressure of 6,000 psi (41.4 MPa), but are available up to a 10,000 psi (68.9 MPa) rating upon request. Standard valves have a straight through flow passage.

SELECTING AN APPROPRIATE SYSTEM

The following tables can be used to select the necessary components for most standard injection/sampling assemblies:

- Nipple and shut off valve to match the tee of the access fitting body - Table 1
- Injection nut - Table 2
- Injection tube length and style - Table 3
- Nozzle type - Table 4 and 5

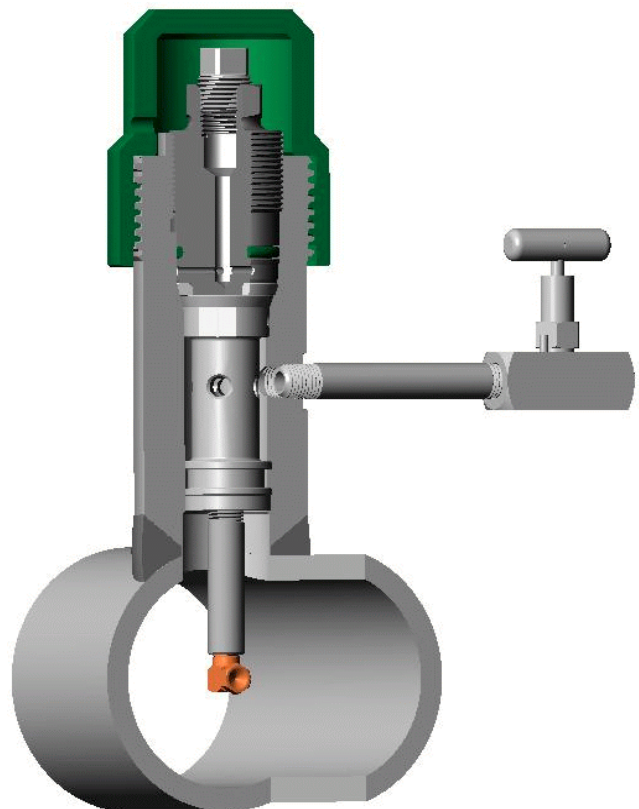

Table 1 - Tee Access Fitting Accessories

Access Fitting Tee Size (NPT)	Valves	Nipples	Pipe Plugs
	316 SS	316 SS Sch 80	Stainless Steel
	Part No.	Part No.	Part No.
1/4" (6.4mm)	10661	10657	11230
1/2" (12.7mm)	10662	10658	11231
3/4" (19.0mm)	10663	10659	11232
1" (25mm)	10664	10660	11233

Note: Select Tee size of equal or larger diameter than that of the injection nut threads.

Table 2 - Injection/Sampling Nuts

Nut Thread Size to Mate with Injection Tube	Nut Length		For Minimal Energy Loss, Injection Rate Should Be Less Than:	
	1.75"	3.25"		
NPT Threads	Part No.	Part No.	U.S. GPM	Ltr. / hr.
1/8" (3.2mm)	38001	10649	0.1	23
1/4" (6.4mm)	13049	10650	0.2	45
1/2" (12.7mm)	38002	10651	0.4	91
3/4" (19.0mm)	38003	10652	0.6	136

1.75" injection nut to be used with 5.25" height fittings

3.25" injection nut to be used with all other height of fittings

Table 3 - Injection/Sampling Tubes

(Tubes have a 1/4" MNPT end to mate with the injection/sampling nut)

Injection/Sampling Tubes (1)						Injection/Sampling Tubes (2)						Injection/Sampling Tubes (3)					
Length Inches	x Open mm	Injection x Quill	Sampling Quill	x 1/4" NPT	Part No.	Length Inches	x Open mm	Injection x Quill	Sampling Quill	x 1/4" NPT	Part No.	Length Inches	x Open mm	Injection x Quill	Sampling Quill	x 1/4" NPT	Part No.
1 1/4	31.8	10667	10737	38737	10806	7	177.8	10690	10759	38759	10829	14	355.6	10714	10783	38783	10853
1 1/2	38.1	10668	10738	38738	10807	7 1/4	184.2	10691	10760	38760	10830	14 1/2	368.3	10715	10784	38784	10854
1 3/4	44.5	10669	10739	38739	10808	7 1/2	190.5	10692	10761	38761	10831	15	381.0	10716	10785	38785	10855
2	50.8	10670	10740	38740	10809	7 3/4	196.9	10693	10762	38762	10832	15 1/2	393.7	10717	10786	38786	10856
2 1/4	57.2	10671	10741	38741	10810	8	203.2	10694	10763	38763	10833	16	406.4	10718	10787	38787	10857
2 1/2	63.5	10672	10742	38742	10811	8 1/4	209.6	10695	10764	38764	10834	16 1/2	419.1	10719	10788	38788	10858
2 3/4	69.9	10673	10743	38743	10812	8 1/2	215.9	10696	10765	38765	10835	17	431.8	10720	10789	38789	10859
3	76.2	10674	10744	38744	10813	8 3/4	222.3	10697	10766	38766	10836	17 1/2	444.5	10721	10790	38790	10860
3 1/4	82.6	10675	10745	38745	10814	9	228.6	10698	10767	38767	10837	18	457.2	10722	10791	38791	10861
3 1/2	88.9	10676	10746	38746	10815	9 1/4	235.0	10699	10768	38768	10838	18 1/2	469.9	10723	10792	38792	10862
3 3/4	95.3	10677	10747	38747	10816	9 1/2	241.3	10700	10769	38769	10839	19	482.6	10724	10793	38793	10863
4	101.6	10678	10748	38748	10817	9 3/4	247.7	10701	10770	38770	10840	19 1/2	495.3	10725	10794	38794	10864
4 1/4	108.0	10679	10749	38749	10818	10	254.0	10702	10771	38771	10841	20	508.0	10726	10795	38795	10865
4 1/2	114.3	10680	10750	38750	10819	10 1/4	260.4	10703	10772	38772	10842	21	533.4	10727	10796	38796	10866
4 3/4	120.7	10681	10751	38751	10820	10 1/2	266.7	10704	10773	38773	10843	22	558.8	10728	10797	38797	10867
5	127.0	10682	10752	38752	10821	10 3/4	273.1	10705	10774	38774	10844	23	584.2	10729	10798	38798	10868
5 1/4	133.4	10683	10753	38753	10822	11	279.4	10706	10775	38775	10845	24	609.6	10730	10799	38799	10869
5 1/2	139.7	10684	10754	38754	10823	11 1/4	285.8	10707	10776	38776	10846	25	635.0	10731	10800	38800	10870
5 3/4	146.1	10685	10755	38755	10824	11 1/2	292.1	10708	10777	38777	10847	26	660.4	10732	10801	38801	10871
6	152.4	10686	10756	38756	10825	11 3/4	298.5	10709	10778	38778	10848	27	685.8	10733	10802	38802	10872
6 1/4	158.8	10687	10757	38757	10826	12	304.8	10710	10779	38779	10849	28	711.2	10734	10803	38803	10873
6 1/2	165.1	10688	10758	38758	10827	12 1/2	311.5	10711	10780	38780	10850	29	736.6	10735	10804	38804	10874
6 3/4	171.5	10689	10759	38759	10828	13	330.2	10712	10781	38781	10851	30	762.0	10736	10805	38805	10875
						13 1/2	342.9	10713	10782	38782	10852						

Injection / Sampling Systems ~ Retrievable

NOZZLES

**Table 4
Atomizing Nozzle**



Spray Characteristics:

- Finest fog of any direct pressure nozzle
- Produces high percentage of droplets under 50 microns.
- Spray pattern is a cone shaped fog
- Spray angle is 90°
- Flush/projecting mount assembly or right angle mount

(1/4" MNPT Connection)

PART NUMBER	ORIFICE DIAMETER (INCHES)	CAPACITY (U.S. GPM) AT VARIOUS PRESSURES						
		30 PSI	40 PSI	50 PSI	60 PSI	80 PSI	100 PSI	200 PSI
11683	0.006			0.006	0.0068	0.0083	0.010	0.013
11684	0.008			0.013	0.014	0.016	0.018	0.025
11685	0.010		0.017	0.020	0.022	0.025	0.028	0.040
11901	0.012		0.023	0.028	0.032	0.037	0.040	0.058
11900	0.015	0.033	0.037	0.042	0.047	0.053	0.063	0.083
11954	0.020	0.058	0.067	0.075	0.083	0.096	0.110	0.150

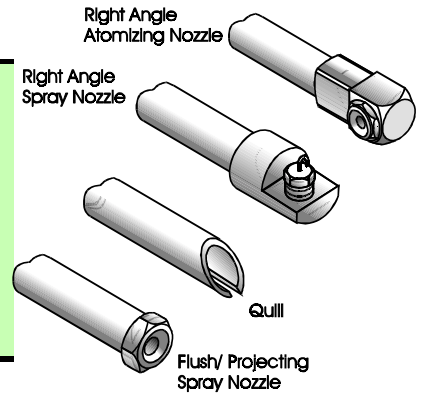

**Table 5
Spray Nozzle**



Spray Characteristics:

- Straight spray nozzle for flush or projecting
- Right angle nozzle for injection parallel to the product flow
- Spray pattern is a wide-angle cone
- Spray angle is up to 120°

(1/4" FNPT Connection)

PART NUMBER	ORIFICE DIAMETER (INCHES)	CAPACITY (U.S. GPM) AT VARIOUS PRESSURES							SPRAY ANGLE @		
		10 PSI	20 PSI	40 PSI	60 PSI	80 PSI	100 PSI	125 PSI	10 PSI	40 PSI	80 PSI
39501	0.055	0.10	0.14	0.20	0.24	0.28	0.32	0.35	120°	120°	90°
39502	0.077	0.20	0.28	0.40	0.49	0.57	0.63	0.71	120°	105°	92°
39503	0.093	0.30	0.42	0.60	0.73	0.85	0.95	1.06	120°	104°	90°
39504	0.109	0.50	0.71	1.00	1.22	1.41	1.58	1.77	120°	107°	98°
39505	0.158	0.75	1.06	1.50	1.84	2.12	2.40	2.70	120°	110°	92°
39506	0.170	1.00	1.41	2.00	2.50	2.80	3.20	3.50	120°	110°	93°
39507	0.188	1.25	1.77	2.50	3.10	3.50	4.00	4.40	120°	110°	94°
39508	0.201	1.50	2.12	3.00	3.70	4.20	4.70	5.30	120°	108°	92°